

GENERAL INFO

CARAVAN / RV FRESH WATER PUMP

A compact pump that delivers pressurised fresh water to caravans and RVs.

Puretec's PT series pumps are designed to deliver pressurised fresh water throughout your caravan or RV. These compact pumps are self priming, run dry safe and quiet, making them the ideal pump for recreational vehicles or trailers.

FEATURES & BENEFITS

- Self priming
- Run dry safe
- Quiet operation
- On-demand use
- Industry standard mounting pattern
- Rubber mounting-base
- Internal bypass technology reduces cycling
- Up to 11.3 Lpm



| | |
|-----------------------|--|
| Ordering Code: | PT-12DC11 |
| Dimensions: | (H) 202.5 mm x (D) 111 mm X (W) 125 mm |
| Priming Capabilities: | 1.8 metres suction lift |
| Voltage: | 12V |
| Max Draw: | 7A |
| Max Temperature: | 60°C |
| Max Working Pressure: | 55 psi (379 kPa) |
| Flow: | 11.3 Lpm |
| Connection: | ½" |

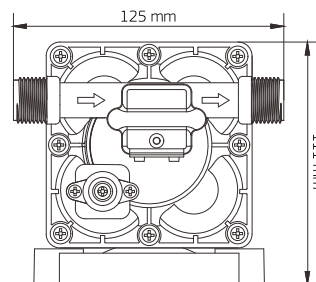
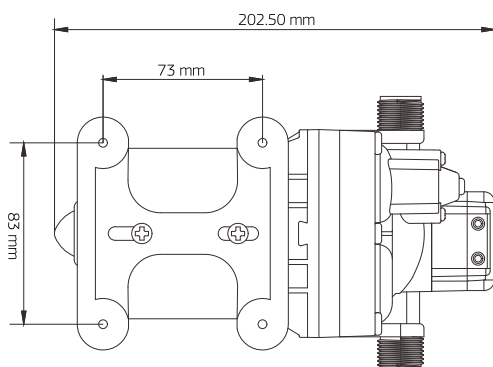

Note:

1. No claims can be made based on the specifications and images in this document. The design, technology, colours, features and prices are subject to change.
2. This document and all its contents are copyright protected. All rights are reserved, particularly alteration, translation and reproduction using electronic systems.
Our Water Filtration Specialists can provide you with advice to suit your needs.